

Product Catalogue

**Specialists
at depth**

Specialists at depth

For the past two decades, K.U.M. has supported leading academic centres around the world by developing bespoke subsea technologies. Today, K.U.M. is the leading provider of subsea data acquisition systems, delivering them either as an end-to-end service from conception through to manufacturing or as off-the-shelf products that are nevertheless highly customisable.

Our vision is to help you make the impossible possible at depth.

Subsea solutions made simple

Discovering our complete end-to-end service

We continue to develop new generations of subsea instruments for customers across a wide range of industries. Our flagship proposition is an end-to-end service that covers designing, prototyping, testing, manufacturing and, where needed, operating unique systems and tools.

Alongside providing this end-to-end service, we can help with a customer's own product development at any stage from design and prototyping through to manufacturing.

We can also provide field support services including system operators on research vessels, instrument training and equipment maintenance.

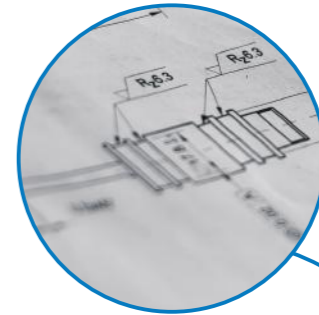

01 Product Design

Transforming innovative ideas into a robust design

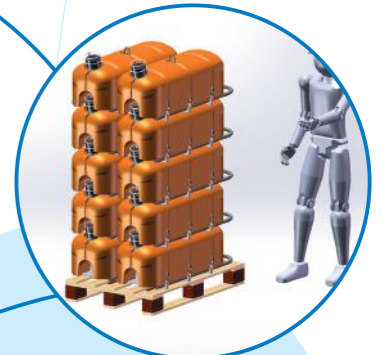

02 Computer Simulations

Performing a range of initial computer simulations



03 Advanced Prototypes

Produced using our highly sophisticated machinery



04 Rigorous Testing

To confirm full conformance to agreed specifications



07 Operator Support

Provision of post-production services including operators



05 Field Trialling

Either in the real environment or at customer facilities



06 Full Manufacture

Inhouse or outsourced to partners for larger volumes

Contents

About K.U.M.	01	Sediment Trap	08	MiniMuc	13
NAMMU	02	Gel-Trap	09	Chain Bag Dredge	14
ISOPOD	04	Lander	09	D-Tubes, Liner Tubes & Storage Rack	14
6D6	05	HiCAP Lander	10	Titanium Pump	15
TOM300	05	Benthic Chamber	10	Materno	15
UHURA & DIRC	06	Syringe Sampler	11	Drive Unit	16
StiK & KIT	06	Stirrer	11	Shackles, Chains & Rings	16
PluK	07	4Tuna	12	Swivel	17
Geophone	07	Pressure Tubes	12	Scoop Net	17
KUMQuat	08	Camera Housing	13		

NAMMU

The world's most sophisticated and reliable OBS

K/MT4230

The founding fathers of K.U.M. had their first encounter with an Ocean Bottom Seismometer (OBS) in 1996. They were immediately fascinated by the combination of high-precision electronics and absolute reliability. A year later, they incorporated as K.U.M. to develop and enhance a range of scientific research equipment for use in the deep sea environment.

In 1999, K.U.M. was part of a scientific expedition that provided the team with first-hand experience of the operation of an OBS, one that was considered to be state-of-the-art at that time. That experience highlighted a number of areas where the team felt improvements could be made. Most notably, they felt the releaser was too big and too heavy, the materials that were used were easily corroded, the quality of the data gathered was poor, and the user interface was completely out of date. With all this in mind, the K.U.M. team decided to address the challenges of building a better system.

In 2001, work began on K.U.M.'s own acoustic releaser designed to eliminate the disadvantages of other models on the market at that time. And, in 2003, K.U.M. launched its first titanium releaser, KUMQuat, which is still considered best in class today.

In the following years, based on interest from several universities, K.U.M. constructed a broadband OBS, which would later be called LOBSTER. This represented the team's first attempt to design a complete OBS system. However, as sophisticated as the LOBSTER was, it was not perfect. So, in 2013, K.U.M. began to develop an OBS that would deliver the team's radical new vision: an OBS that would offer both the highest performance and lowest energy consumption, yet simultaneously be small and safe enough to use on the deck of a vessel in open seas.

The design of this new OBS was so promising that the development work was supported by the German state of Schleswig-Holstein and by the European Union. After two and a half years of development work, K.U.M.

proudly presented a new deep sea OBS concept called NAMMU; this was truly a state-of-the-art instrument that received significant market attention from the moment it was launched.

Since then, NAMMU has proven itself on dozens of missions, with its data quality, reliability and user-friendliness resulting in widespread enthusiasm for the concept.

In contrast to earlier models, the buoyancy shell of the NAMMU is designed to simultaneously protect the sensitive sensor system from shocks and accidental impacts during transportation, deployment and recovery. The sensor is located directly at the bottom of the pressure tube and has direct contact with the anchor, which is crucial for good coupling. The anchor itself, like the OBS, is asymmetrical in weight distribution so when the two come together, the complete system has no tilt during descent and lands on the seabed perfectly level.

During recovery, when the anchor is released, the OBS ascends and resurfaces vertically with a flashing beacon and orange flag sticking high up out of the water for clear visibility and speedy recovery. All parts exposed to seawater are made of either polyethylene or titanium; the result is a highly robust, fully saltwater-proof instrument that is perfect for long-term use.

The data logger is continuously enhanced for precision, robustness and low energy consumption. With a signal-to-noise ratio on four channels of over 142 decibel and with only 125mW energy consumption, this is a high-performance piece of kit. Equally impressive is a 120 Sec broadband

seismometer, which works completely autonomously and with a precisely tuned dynamic range. The unit's total energy consumption is less than a third of a watt and thus, despite its small size, data can be recorded continuously for up to 13 months and with a battery backpack extension for up to 36 months.

The memory drive unit is simply plugged in from the outside and the complete instrument is operated via Wi-Fi and the browser. It is all part of what makes NAMMU as user-friendly as the TV in your living room.

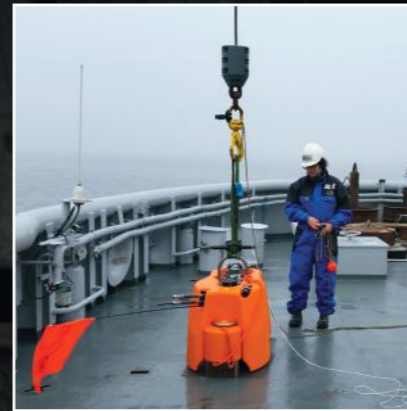

“an elegant design throughout”

NAMMU:

An elegant design throughout

THE DEPLOYMENT

Up to 50 units can be transported in one 20-foot shipping container. Easy and intuitive programming is offered over a web interface via Wi-Fi – accessible from your laptop or smartphone. No special software is required. Usually a free-falling system, it can also be deployed by ROV.

THE EXPERIMENT

Deployments of up to three years are possible due to low power consumption with reliable storage of vital instrument data and metadata. Good coupling is facilitated through a compact instrument design and an aquadynamic shape enables industry-leading low levels of external noise.

THE RETRIEVAL

Extremely reliable acoustic release is key for retrieval. Other features include quick location of the instrument with radio beacon and flasher, as well as fast data download via external memory StiK. Easy, fast data conversion to mSEED is possible via our portable open-source software.

TECHNICAL DATA	
Weight with 80 Li-Cells	In air (in salt water)
Weight without anchor	156 kg (-13 kg)
Weight with anchor	205 kg (30 kg)
Weight of pressure tube	45 kg (33.6 kg)
Weight of releaser KUMQuat	11 kg (6.4 kg)
Maximum operation depth	6000 m
Maximum operation time	14.5 months (80 LiThCl D-cells) 36 months with optional battery backpack unit
Size without flag w × h × d	635 mm × 770 mm × 800 mm
Anchor size	800 mm × 600 mm
Seismic Sensors	120 sec broadband seismometer or 4.5 Hz Geophones
Pressure Sensor	100 sec Hydrophon HTI-04-PCA ULF or Differential Pressure Gauge (DPG) or Absolute Pressure Gauge (APG)
Data Logger	K.U.M. 6D6: 4 channels at 32bit at 142db
Releaser	KUMQuat 562



Datalogger 6D6

The Datalogger 6D6 is a flexible data acquisition system with the lowest power consumption on the market and outstanding data quality. It features an easy-programming interface accessible via Wi-Fi and large storage capacities to enable extended deployment of up to three years.

Frame

Made from corrosion-resistant titanium and durable syntactic foam, the frame offers buoyancy in a shock-resistant and robust package that can easily endure the forces of the sea. The unit's small size makes it possible to deploy more systems than ever before.

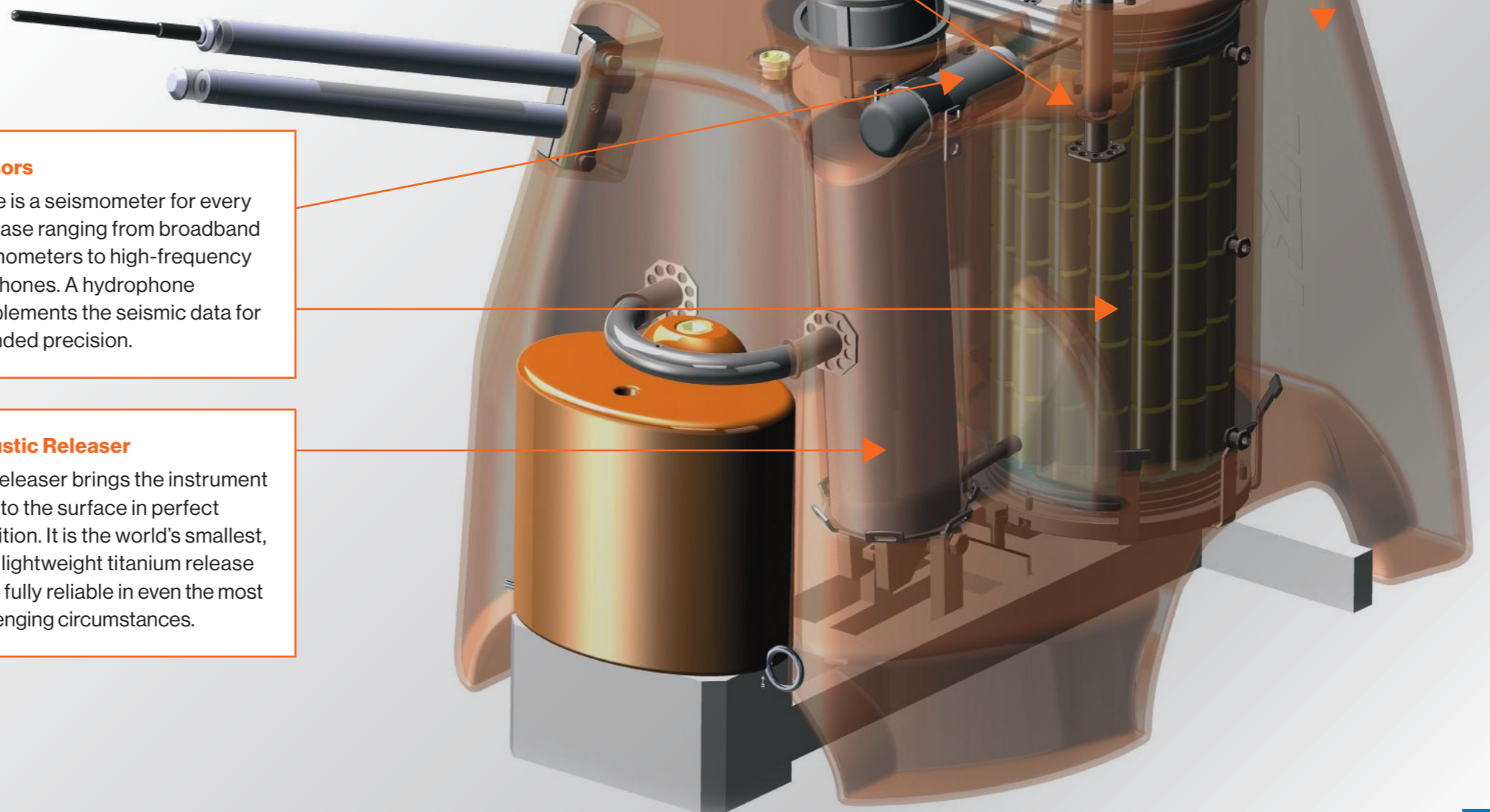

Sensors

There is a seismometer for every use case ranging from broadband seismometers to high-frequency geophones. A hydrophone complements the seismic data for extended precision.

Acoustic Releaser

The releaser brings the instrument back to the surface in perfect condition. It is the world's smallest, most lightweight titanium release unit – fully reliable in even the most challenging circumstances.

ISOPOD

The smallest and most lightweight OBS on the market

K/MT4231

K.U.M. had great success from the start with NAMMU. However, the team was soon faced with an interesting challenge: how to develop a new, more compact, short-term OBS system that would carry only the OBS essentials in an even smaller, more cost-effective package.

K.U.M.'s answer to this challenge was a new OBS that is called ISOPOD.

ISOPOD is designed to deliver the best results by autonomously recording seismic data for over three months in water depths of up to 6000m. It is equipped with three 4.5Hz geophones, a hydrophone, an ultra-low-power four-channel datalogger 6D6 and an acoustic releaser, which is integrated into the main pressure tube to save weight, cost and set-up time.

ISOPOD is also equipped with the external memory StiK which can be exchanged in seconds and redeployed without opening the pressure case. And, with a total weight of only 95kg, ISOPODs can easily be stacked for transportation with up to ten units fitting on a standard pallet.

Without any compromise on quality or reliability, ISOPOD is as small and lightweight as a short-term OBS possibly can be.

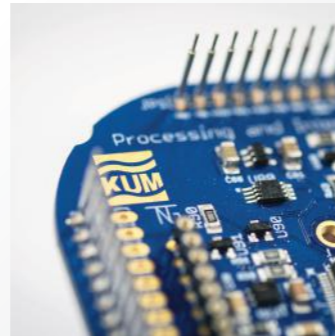

MECHANICAL DATA	
Size	1200 x 400 x 365 mm
Weight	95 kg fully equipped
Frame	Titanium (TiAl6V4)
Pressure tube	Titanium (TiAl6V4)
Buoyancy	Syntactic foam

ELECTRONICS DATA	
Data logger	Ultra-Low-Power "6D6", 125 milliwatt @ continuous recording, 4 channels @ 32 bits, up to 4000 sps
Geophones	4.5Hz resonance frequency, XYZ-orientation Hydrophone: HTI-04, optional DPG, optional APG
Release	Mechanical-acoustic, optional additional time release
Location	2m high visibility flag, flash unit, radio beacon, Iridium Satellite Positioning package (optional), AIS Marine Traffic package (optional)

ACOUSTIC RELEASER

Proven technology in a new guise. The motor-driven releaser is integrated into one larger housing together with the geophones, batteries and data logger.

ACQUISITION SYSTEM

Adapted for 4.5Hz geophones, the data logger demonstrates extraordinary performance both in data quality and power consumption. It makes ISOPOD the perfect tool for active seismic operations with up to three months of continuous data acquisition.

DESIGN

Trimmed back to the essentials, both the frame and the buoyancy equipment are designed for efficient manufacturing and ease of use. Assembly can be completed within minutes by one person and 12 assembled ISOPODs can be stacked on a standard pallet for transportation.

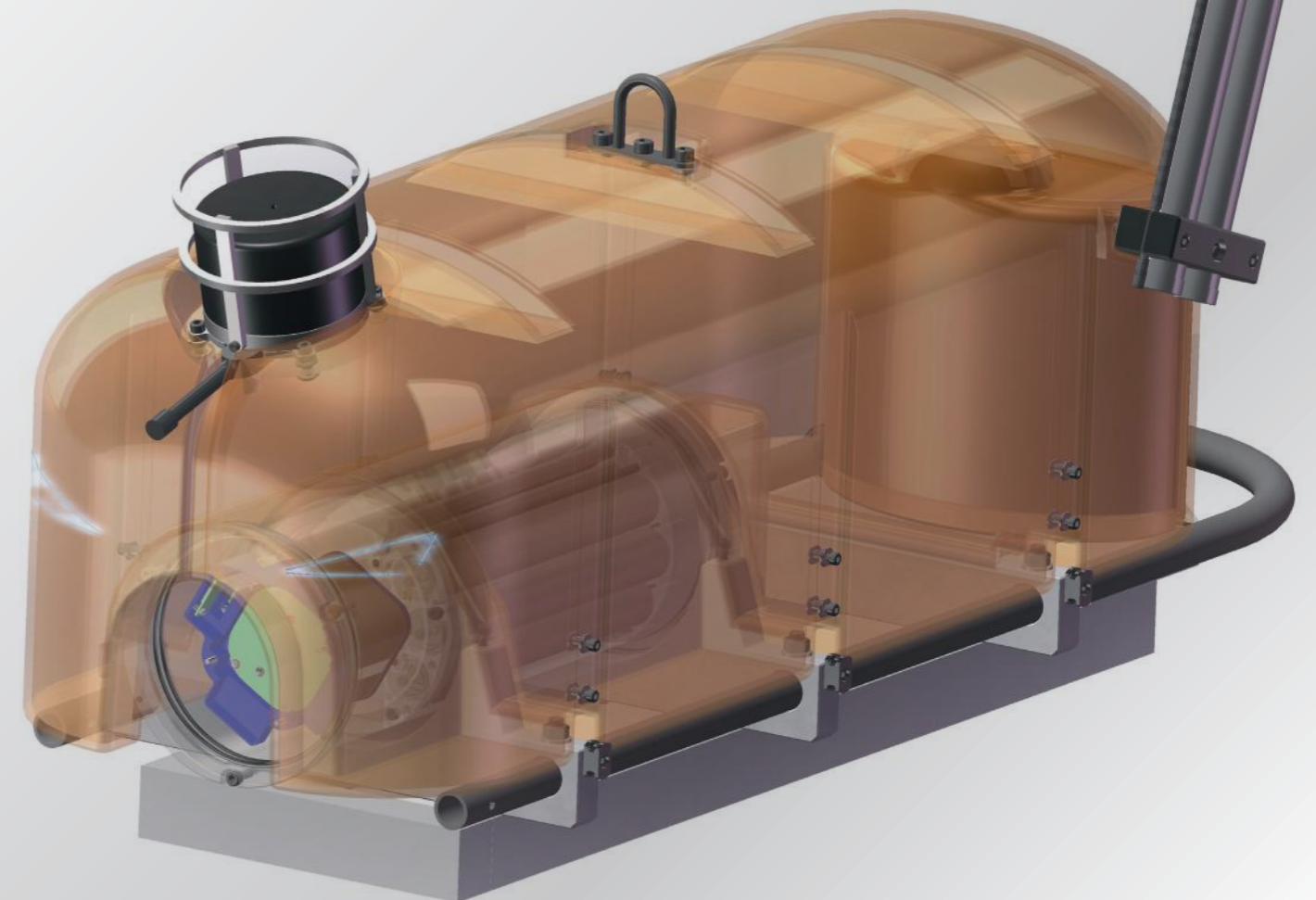

The complete marine data logging solution

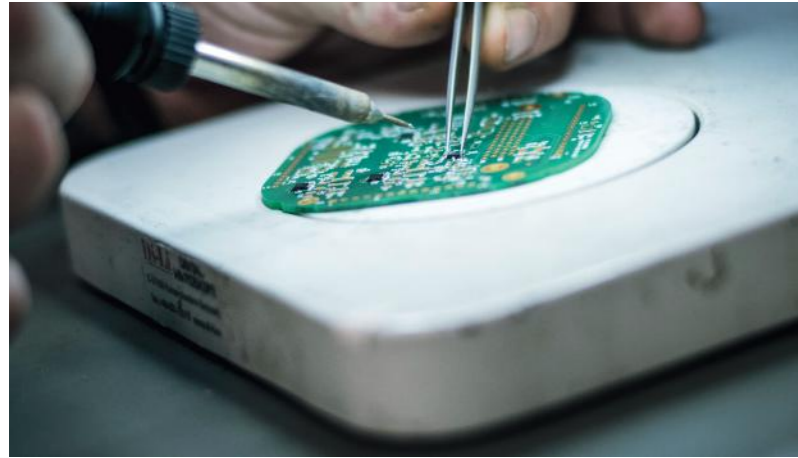

Data collection is one of the most essential factors in any subsea operation, if not the most essential. The collection and accurate recording of data must be carried out to a high standard across the lifetime of a project, which can run for months and sometimes years.

Despite this requirement, many traditional data loggers have often struggled in the marine environment due to limited measuring capabilities and high power consumption, which in turn leads to very short operational timelines.

K.U.M. has put over 20 years of experience in marine seismic operations into tackling this issue. The result is the development of the 6D6 Data Logger for use in both K.U.M.'s own OBS systems and third-party subsea devices.

Where other data loggers are limited in channel recording capabilities, the 6D6 has been designed to record up to seven channels simultaneously. It also uses very little power without sacrificing performance, while its precise crystal oscillator allows for data collection to be conducted for an extended period with minimal downtime.

The 6D6 is pre-set with four channels and an optional 'Plug-on' mode offers potentially up to seven channels to meet the specific needs of customers.

The innovative modular design of the 6D6 allows for the installation of further AD-boards and/or a CSAC clock. Additionally, the clock is buffered internally to ensure safe synchronisation regardless of battery issues.

The basic configuration of the 6D6 features an integrated web interface via an access point within a DIRC unit. If connected to DIRC, Wi-Fi connection is established, and any web browser can then be used to program the 6D6.

Application:

- K.U.M. OBSs (NAMMU)
- Any subsea data collection systems

Features / Benefits:

- User-guided, foolproof step-by-step-operation
- Low power consumption
- 'Plug-on' mode for additional channels
- Data storage independent
- Internal buffer battery for clock (to protect synchronization)
- Compatible with all browsers
- 10 second buffer against accidental battery disconnection
- Automatic web server shutdown when disconnecting programming cable

6D6	
Channels	3 x Seismometer, 1 x Hydrophone
AD-modules	Geophone; Seismometer, DPG; Hydrophone, APG, etc.
Additional options	Integrated GPS, AIS, upgradable up to 7 channels
Clock	TOM300 (0.02ppm non-linearity)
Data conversion software	m-SEED
Data storage	StiK / SD Card (up to 2 TB)
Resolution	32 bit @ 250 sps
Memory	Up to 2 TB (With hot swap)
Network	Wi-Fi
Ports	24 I / O (Instrument control)
Sample rate	50 – 4000 Hz
Signal – noise ratio	142 dB
Power consumption	125 mW (Recording mode)
Dimensions	Length – 80 mm, Width – 80 mm, Height – 80 mm
Weight	0.290 kg

A highly accurate timing oscillator module

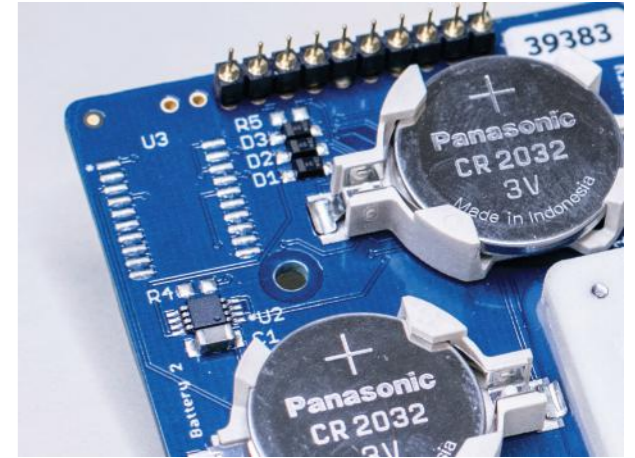

During any seismic operation, the recording and collection of accurate timestamps is essential to ensure the reliability of the data set. Inaccurate time data can cause significant errors in data processing and interpretation and may lead to incorrect conclusions. This task is especially difficult when working on the seabed where no GPS, clock or power source is available.

To address this K.U.M. developed the TOM300 – a highly accurate timing oscillator module. This device features a high-speed internal clock that generates high-resolution timestamps of 1µs. When synchronised with GPS or alternative systems both before deployment and after recovery, the remaining non-linearity after correction is as low as 0.02ppm.

The TOM300 is extremely versatile. It can easily be integrated with a range of different instruments and is perfect for use across a wide scope of deep-sea investigations. It features low power consumption as well as a standby mode, which allows for an extended operational time of up to five years on the main battery. And, if that is insufficient, then a back-up battery offers an additional five years of operational time.

Application:

- Timestamp management device for places where time synchronisation is not possible (due to absence of GPS / GLONASS / BEIDOU / GALILEO / radio)

Features / Benefits:

- Low error range over vast temperature range
- High-speed internal clock
- Low power consuming standby mode

TOM300	
Timestamp resolution	1µs
Absolute time error	< 200 ns/s
Memory	256 bytes
Protocol interface	I2C
Non-linearity after correction	0.02 ppm
Power consumption	< 500 µW Active mode < 10 µW Power save mode
Operational time	Up to 10 years (2 x CR 2032)
Operational temperature range	-10°C to +80°C
Dimensions	Length – 52 mm, Width – 52 mm, Height – 9 mm

A tried and tested marine GPS-receiver and distribution box



For any seismic data acquisition work, one of the most precious pieces of information is the exact time. Every OBS needs to be time synchronised so that data can be compared based on timestamps. Precision is paramount.

GPS is the most common method of synchronisation used today. However, many low-cost GPS receivers lack a pulse-per-second (PPS) signal and their time measurement usually has high latency and jitter. Fortunately, our GNSS antenna, UHURA, is designed to work with GPS, GLONASS, Galileo and BEIDOU.

UHURA provides NMEA-data using RS485 with both 4800 baud and 9600 baud. An extra line provides a latency-free, DCF77 encoded PPS signal. This makes it possible to achieve precise synchronisation of systems that would otherwise need an extra radio receiver.

UHURA can be equipped with cable lengths of up to 100m, and the connecting plug can slip through orifices of 20mm diameter. It can be fixed to vessel railings with the provided clamp and is designed to withstand strong winds and temperatures ranging from between -10 to +85°C.

UHURA is connected to the distribution box DIRC for its power supply and to enable the distribution of data. DIRC is the control centre for the OBS, ensuring optimal time synchronisation, positioning and data recovery – all within a robust, compact, lightweight, waterproof and dustproof case.

DIRC allows the user to connect a PC to both the OBS data logger and UHURA for time synchronisation and for data collection either through an SD-card or StiK port. DIRC can also accommodate an external hard drive for additional storage capacity. Finally, DIRC can establish a wireless access-point to communicate with the data logger using any Wi-Fi enabled device.

Application:

- **OBS and other subsea or underground systems requiring time synchronisation and data collection**

Features / Benefits:

UHURA:

- **Very fast Time-to-First-Fix**
- **Shock-resistant**
- **Waterproof**
- **LED status indicator in a housing**

DIRC:

- **Waterproof**
- **Dustproof**
- **Breakproof**

UHURA	
Protocol	NMEA via RS485 @ 4800 baud and 9600 baud
Supported positioning systems	GPS, GLONASS, Galileo, BEIDOU
Timing information	PPS-line DCF77 coded
Power consumption	5 Volt operation (USB)
Cable length	up to 100 m
Operational temperature range	-10 to +85°C
Dimensions	Diameter – 140 mm, Height – 95 mm
IP value	IP67

DIRC	
Ports	USB, Ethernet, SD-card, StiK, Wi-Fi
OBS compatibility	NAMMU, LOBSTER, ISOPOD
Memory	External hard drive, SD card reader, StiK
Operational temperature range	-10 to +50°C
Dimensions	Length – 228 mm, Width – 182 mm, Height – 92 mm
IP value	IP54

A quick-access marine data storage device



Data storage in marine environments has long presented the offshore industry with great difficulties. Recovery of a data storage device from a seabed station requires the equipment housing to be opened, which is often no small task considering how secure deep-sea housings can be.

Bad weather offshore can make the task even more challenging, doubly so if the same station needs to be redeployed again with new data storage.

Now imagine a thumbsize data container that is pressure resistant to full ocean depth, attached to the outside of the desired instrument and capable of being easily removed and swapped directly after recovery. No housing openings, no fiddling with stubborn connections, just unplug the storage device in a minute and attach a new one.

This compact and versatile storage device is StiK. StiK accommodates all marine data storage requirements. Made from titanium, K.U.M.'s durable and portable storage device features double O-ring sealing and offers an operational depth of 12km, making it perfect for subsea research.

To further enhance data recovery offshore, K.U.M. has developed a high-grade compact memory card reader dubbed KIT which is designed to work optimally with StiK, SD cards and other data storage devices. KIT delivers a reliable method of transferring data from different storage devices to a portable computer or any other system via a simple USB connection.

Application:

- **K.U.M. OBSs (NAMMU)**
- **Any subsea data collection systems**

Features / Benefits:

- **Quick removal or swap**
- **Pocket size**
- **Double 'O-ring' sealing certified to 12 km**
- **Plug includes gold plated pins for low transition resistance**
- **Non-corrosive titanium build**

STIK	
Capacity	64GB – 128GB – 256GB – 512GB – 1024GB
Data formats	exFAT, FAT32, Ext4, proprietary formats
Data transfer speed	32 Mbit/s
Ports	1 x Pluk
Power consumption	Write access – 250 mW, Idle – 0.2 mW
Operational depth	12000 m (full ocean depth)
Dimensions	Diameter – 20 mm, Length – 50 mm
Material	Titanium (TiAl6V4)

KIT	
Ports	1 x USB 2.0, 1 x SD card, 1 x Pluk
Power source	USB
Dimensions	Length – 80 mm, Width – 80 mm, Height – 80 mm

A versatile and reliable deep-sea connector

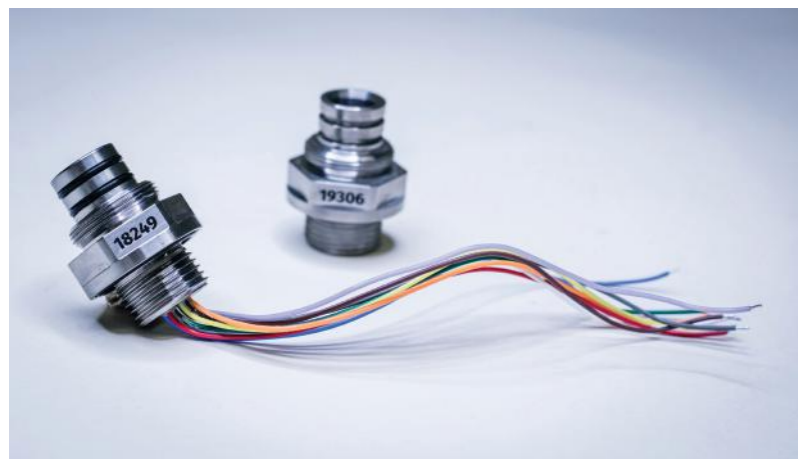

There are many different underwater connectors on the market. However, if for example, you are looking for a connector with a small diameter, an operational depth of more than 7300m, high current capacity and a fully customisable number of pins, then you will find there are very few options available.

However, one of those few is PluK – K.U.M.'s unique deep-sea connector.

PluK is the most versatile, flexible and economic deep-sea connector available on the market. It features a double O-ring sealing, hundreds of unique pin configurations, ocean depth resilience, compact size and a highly durable titanium construction.

PluK was initially developed for internal use only, but K.U.M. soon realised there was high demand for such connectors. Today, PluK provides a market-leading solution for many of the deep-water connection needs encountered by subsea professionals.



Application:

- Deep-sea connector

Features / Benefits:

- Compact design
- Flexible number of pins
- Highly versatile number of connection options for a wide array of use cases

PLUK	
Connections	Ethernet, USB, fibre optics, hybrid (electrical / fibre optics), hybrid (high power / sensor inputs), twist-proof, gold plated and leading pins
Number of pins	Up to 30
Compatibility	StiK
Material	Titanium (TiAl6V4)
Operational depth	12000 m
Dimensions	Diameter – 30 mm

A flexible, low-frequency deep-sea geophone

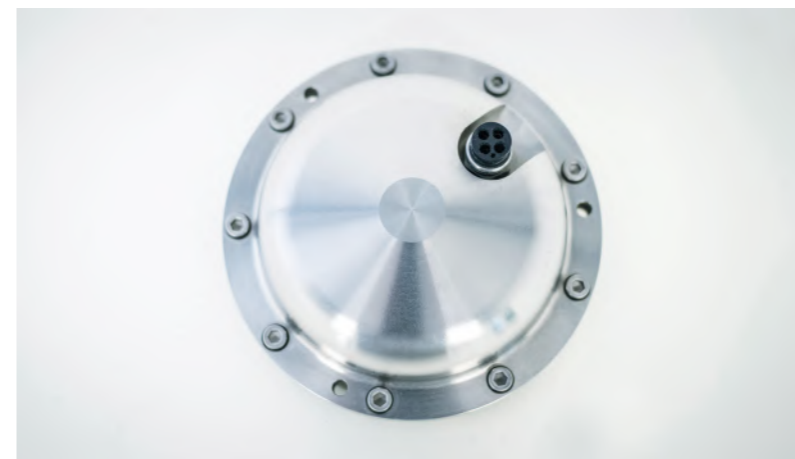

Ground motion measurement is a vital source of data, providing valuable information on subsurface lithology and structure both on land and at sea.

While onshore investigations are straightforward, offshore they can often pose a range of difficulties such as time limitations due to high power consumption, noise interference from currents, and poor seabed coupling. And while broadband seismometers in OBSs are now relatively common, they can be too large and expensive for use on many operations (e.g. active seismic projects where higher frequency signals are recorded).

To address this, K.U.M. has developed a standalone subsea Geophone to optimise the accuracy of data collection. It delivers outstanding signal-to-noise ratio with a special pressure housing for 3C-Geophones that resides externally from the main instrument and is connected by just a flexible cable. This way, the Geophone is decoupled from any possible unwanted noise produced by the main instrument itself (e.g. the OBS) that may lead to inaccuracies within the data.

Our three-part Geophone features a compact, grooved titanium design tailored to ensure best seafloor coupling while simultaneously providing excellent protection from corrosion. The Geophone is best used with a range of K.U.M.'s OBS instruments, all of which have been designed and tested together. However, the device is equally compatible with a wide range of third-party instruments.

Application:

- Subsea seismic data acquisition as part of the K.U.M. OBS or any other marine instrument

Features / Benefits:

- Compact design
- Optimised grooved shape for best seabed coupling
- Implemented gravity for free fall
- High signal-to-noise ratio
- Light and corrosion-resistant titanium
- Low noise irrespective of current

GEOPHONE	
Frequency range	4.5 Hz – operates at +/-30 deg 10 Hz – Omnidirectional 14 Hz – Omnidirectional 30 Hz – Omnidirectional
Damping (open circuit)	0.56 % (±5%)
Moving mass	0.0111 kg
Sensitivity (open circuit)	28.8 V/m/s (±5%)
Sensors	3 orthogonal geophones
Material	Titanium (TiAl6V4)
Operational depth	6000 m
Dimensions	Diameter – 160 mm, Height – 57 mm
Weight	2.6 kg (air), 1.6 kg (water)

The world's smallest titanium deep-sea acoustic releaser

For many years, the only acoustic release systems available for deep-sea missions were either stainless steel heavy-duty 1000kg release load or aluminium shallow water 30kg release load. There was nothing in between.

Which is why K.U.M. developed KUMQuat. It is a lightweight, deep-sea, corrosion resistant, acoustically controlled releaser that can not only be used with K.U.M. equipment but also by developers in the wider global market.

KUMQuat comes in two versions – lightweight and heavy load. Both can be used either in-line (inside of a rope, wire, chain), where buoyancy is attached to the rope above and weights are attached to a rope below (conventional mooring), or as a part of an instrument where the ground weight is attached below (OBS or lander). Both are entirely built from titanium and are certified to operate at depths of up to 10000m depending on customer requirements.

The release mechanism is controlled either via an external acoustic signal or through an integrated timer. Furthermore, KUMQuat offers the advantage of three additional output lines. When combined with an input line this allows for the remote control or status check of other instruments via its acoustic receiver.



Application:

- In-line mooring release
- Weight release for subsea instruments
- Control of other instruments via acoustic receiver

Features / Benefits:

- Robust corrosion-free titanium build
- External acoustic remote control
- Optimised to work with PACS & 8011M deck boxes
- User command input available
- Time based release

KUMQUAT	
Models	Lightweight (K/MT 562 and K/MT 573 (in-line)) and Heavy load (K/MT 552 and K/MT 572 (in-line))
Release load	Lightweight – 250 kg, Heavy load – 1000 kg
Safe working load	Lightweight – 500 kg, Heavy load – 2500 kg
Reply frequencies	7.5 – 15 kHz (0.5 kHz increment) Standard: 12 kHz
Reply pulse width	8.5 ms – 17 ms
Command coding	FSK 16 bit, 12000 individual codes available
Commands	Release, Range ON, Range OFF, Three individual I/O commands
Input / output capabilities	3 x external device controller 1 x input line for external device checks
Power supply	2 x 6 Alkaline C-cells (baby)) optional Lithium batteries
Battery life	24 months (with 1.9 times safety), 100 x releases, 3,000 x pings
Quiescent power consumption	4 mW typical
Material	Titanium (TiAl6V4)
Operational depth	6000 m optional 10000 m
Dimensions	Diameter – 110 mm, Length – 625 mm
Weight	Lightweight – 11.1 kg (air) / 6.3 kg (water) Heavy load – 13.6 kg (air) / 7.7 kg (water)

A robust and durable subsea particle collector

The collection of sinking particles is an essential part of many marine investigations. Such particles offer insight into the migration of trace elements and nutrients, ancient ocean circulation patterns and many other parameters. To obtain this data, an instrument is required to collect samples while remaining protected from both high-pressure environments and corrosion risks often for long periods of time.

To meet this need, K.U.M. developed the Sediment Trap. Built to the highest standards to ensure the optimal collection of particles in the water column, the Sediment Trap can be deployed in both salt and fresh water and up to depths of 10000m.

The hexagonal open framework reduces interfering current resistance and enables sinking sediment particles to be collected. Particles are funnelled via a special hexagonal lattice-grid baffle, sealed in special paper and then collected into sample bottles.

The bottles are held within a sample collection turntable where they can later be analysed to determine biological, chemical and mineralogical compositions. The duration of sample collection can be programmed via a cable or Wi-Fi connection from one minute to 24 months.

Extra care has been taken to ensure there is no contamination of the probes collected. All parts are made from GRP resin and the funnel is carefully polished, ensuring that particles do not stick to the funnel wall and no interfering chemicals from the plastic can contaminate the probe samples. Each probe is individually sealed by its own spring to ensure that, even after long investigation periods, the probes remain pure.



Application:

- Subsea collection of sinking particles

Features / Benefits:

- Hexagonal shape allows connection of several traps to cover wider area
- Hexagonal lattice grid stabilizes current and reduces wash out
- Sleep mode

SEDIMENT TRAP				
Product	K/MT 236	K/MT 320	K/MT 234	K/MT 322
Collection area (m²)	0.25	0.5	0.5	0.5
Sample bottles	14	41	21	21
Sample bottle volume (ml)	400	400	400	400
Funnel slope angle (°)	34	34	34	34
Connection interface	Wi-Fi	Wi-Fi	Wi-Fi	Wi-Fi
Power supply	9V DC (6 Alkaline 1.5V batteries)	9V DC (6 Alkaline 1.5V batteries)	9V DC (6 Alkaline 1.5V batteries)	9V DC (6 Alkaline 1.5V batteries)
Operational depth (m)	Up to 3000	Up to 6000	Up to 6000	Up to 10000
Operational temperature range	-10°C to +40°C	-10°C to +40°C	-10°C to +40°C	-10°C to +40°C
Operational time	Up to 24 months	Up to 24 months	Up to 24 months	Up to 24 months
Total height (mm)	1480	2230	1900	1900
Width (mm)	910	1146	1079	1079
Funnel height (mm)	940	1313	1313	1313
Funnel Ø (mm)	565	800	800	800
Weight (kg)	53 (air), 38 (water)	131 (air), 62 (water)	98 (air), 42 (water)	100 (air), 45 (water)
Attachments	Single side suspension 3 point suspension (optional)	Single side suspension 3 point suspension (optional)	Single side suspension 3 point suspension (optional)	Single side suspension 3 point suspension (optional)

A subsea trap for individual particle collection and imaging

While the K.U.M. Sediment Trap is designed to catch as many particles as possible with the use of a large funnel, the K.U.M. Gel-Trap is designed for the collection and identification of specific particles. This offers a unique approach to better understanding particle movement through the ocean.

Instead of a funnel, a well-defined tube is used with a highly polished surface. The conventional sample bottles used in the Sediment Trap are replaced by cylindrical glass probes, which are made from polished PMMA and filled with a viscous liquid (gel). Once a particle has been captured in the gel, the sinking velocity is reduced, and the particle slowly descends to the base of the probe.

Thereafter, a high-resolution camera can take photographs of the probe at any given time. This enables any individual particle to be clearly identified, measured and its behavioural properties analysed.



Application:

- Underwater collection of specific sinking particles
- Provides photo of desired particle in collection area

Features / Benefits:

- Unique pictures of individual particles

GEL-TRAP	
Collection area	908 mm ²
Sample bottles	24 or 41
Sample bottle volume	80 ml
Funnel slope angle	0°
Connection interface	Wi-Fi
Power supply	9V DC (6 Alkaline 1.5V batteries)
Operational depth	6000 m
Operational temperature range	-10°C to +40°C
Operational time	Up to 24 months
Dimensions	Height – 1.340 mm, Width – 1.146 mm
Weight (kg)	110 kg (air)
Attachments	Single side suspension 3 point suspension (optional)

A robust and customisable seabed instrument carrier

Obtaining data directly from the seabed can be of high value but can be a complex operation. Many different instruments are available to conduct seabed investigations, but the transportation of this equipment to and from the seabed poses many challenges. These include limited carrying ability, storage issues, limited power supply and inaccurate deployment.

To address those challenges, K.U.M. developed the Lander, a carrier that has been designed to cater for all subsea instrument transportation and deployment needs.

Attached to the Lander, instruments can be carefully lowered to the seabed aided by a video-controlled launcher. Once in the desired location, the Lander can be left autonomously until the research is concluded. At this point, an acoustic signal or time release alerts steel weights to drop and the Lander rises to the surface for recovery.

The Lander is equipped to carry multiple instruments simultaneously. The basic frame is comprised of an open tripod with weights, float units, radio beacon and strobe lights.

With its lightweight, corrosion and pressure-resistant titanium build, the Lander is effective to an operational depth of up to 6000m. In addition, the Lander can be designed to customer requirements to achieve the best execution for specific operations.

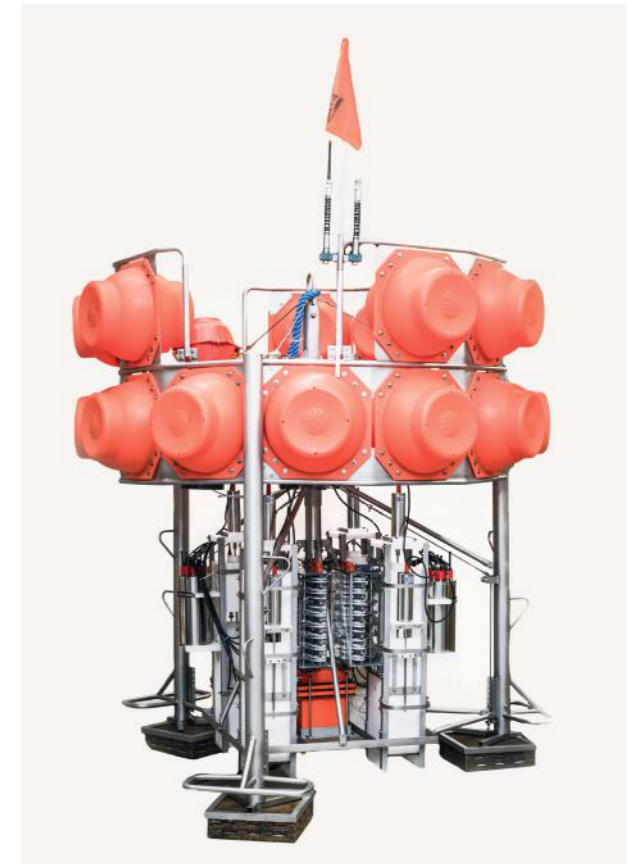

LANDER	
Payload (marine instruments)	Steel frame: 210 kg max, titanium frame: 260 kg max
Buoyancy	Glass spheres with protection shells (max 21"x17" spheres). Syntactic foam
Deployment speed	0.5 – 1.0 m/s
Material options	Steel Titanium (44% lighter)
Operational depth	Up to 6000 m
Dimensions	Diameter – 2200 mm, Height – 2500 mm
Basic equipment	Open frame, three legs, weights, instrument carrier, float units
Optional equipment	Flash, radio beacon, flag to aid location, benthic chamber, syringe sampler, video camera, sediment trap, ADCP, EDDY-correlation, CTD, turbidity

POSSIBLE EQUIPMENT		
Part of lander	weight on air	in salt water
Lander frame	217 kg	192 kg
Release unit (2 pcs.)	25 kg	15 kg
Benthic chamber (3 pcs.)	114 kg	69 kg
TUNA-tube (2 pcs.)	72 kg	36 kg
Syringe sampler (3 pcs.)	51 kg	27 kg
Glass buoyancy (21 pcs.)	473 kg	minus 535 kg
Complete system approx.	950 kg	minus 195 kg
Ground weight (3 pcs.)	450 kg	395 kg
Complete system with weight approx.	1400 kg	200 kg

Application:

- Transportation to the seabed, deployment and recovery of marine instruments
- Deep-sea laboratory for use in multiple disciplines

Features / Benefits:

- Steel or titanium options available
- Allows for multiple instruments to be attached
- Fully customisable according to customer requirements
- Ballasted for negative buoyancy

A high-capacity multidisciplinary seabed observatory

The High Capacity and Payload (HiCAP) Lander is a modular multidisciplinary seabed observatory – which K.U.M. has recently improved for near-bottom investigations through the addition of multiple sensors (including CO₂, CH₄, redox and EDDY correlation sensors).

Capable of carrying a wide range of instruments, HiCAP allows for biological, physical, chemical or geological parameters to be measured across a 5.4m² area of the seabed during short- or long-term operations, depending on the customer requirements. Made from titanium, GRP and syntactic foam, the K.U.M. HiCAP reduces the risk of collected samples being contaminated and offers excellent protection from corrosion and pressure.

For deployment, an anchor is attached to create negative buoyancy and the unit descends to the desired seabed location at a speed of between 0.5 – 1.0 m/s. During recovery, an integrated acoustic releaser separates the anchor frame from the main segment. In case of failure, the HiCAP features an identical backup acoustic releaser that is always ready for use. Alternatively, the acoustic releaser may be deactivated, and release initiated manually by an ROV. The use of an ROV also offers the option to attach a wire rope to the Lander for recovery together with the anchor using a vessel crane.



Application:

- **Transportation to the seabed, deployment and recovery of marine instruments**
- **Deep-sea laboratory where contamination-free probes are essential**

Features / Benefits:

- **Riskless operation of ROV and AUV thanks to syntactic foam**
- **Can be dismantled for storage purposes**
- **Allows for transport of multiple instruments**
- **Variety of syntactic foam quantity and sizes available**
- **Titanium / GRP material for zero probe influences**
- **Non-magnetic for EM-measurements**
- **Huge area to support multidisciplinary investigations**
- **Relay station for satellite landers via acoustic communication**

HICAPLANDER	
Max payload	400 kg (in water)
Base area	5.4 m ²
Floatation	Syntactic foam (quantity and sizes variable)
Localisation	Radio beacon and flasher
Material	GFK, titanium and PP (passive and non-magnetic)
Operational depth	Up to 6000 m
Dimensions	Height – 3.60 m (with anchor frame)
Weight	2000 kg (with launcher)
Example of compatible instruments	Sediment trap CTD system ADCP (Acoustic Doppler Current Profiler) Remote Transducer / Modem Telemetry Camera

A seabed penetrator / extractor for in-situ experiments

The direct analysis of seabed sediment can be a critical part of any marine investigation. However, the collection and sealing of the sediment, while also allowing for experiments to be conducted in-situ is a very difficult task.

To address this challenge, K.U.M. designed the Benthic Chamber, which is capable of penetrating the seabed and collecting a sediment probe sample along with 20-litres of the seawater column directly above it.

The Benthic Chamber allows for simultaneous experiments and analysis of the seabed-water contact to be completed via the on-board Syringe Sampler (K/MT 115) and various chamber sensors.

Deployment of the Benthic Chamber to depths of up to 6000m is carried out using the K.U.M. Lander. The chamber consists of two components, the rack and the chamber with blind. The rack moves the chamber towards the seabed and allows penetration to begin; once drilling is complete the blind closes and embraces the sediment probe in the chamber.

At this point in-situ measurements can take place through the injection of desired elements such as oxygen or CO₂ via the onboard Syringe Sampler. Changes can be measured in-situ via the onboard sensors in the chamber (e.g. CO₂, O₂, CH₄) at different time intervals. During this time, the remaining syringes can collect samples from the chamber at any time.

When the operation is concluded, the rack moves the chamber up once more and the sample is safely stored.



BENTHIC CHAMBER	
Drives	Standard drive for deep sea application Weight – 5.4 kg Voltage – Up to 12V
Material	Chamber & blind – POM Drives – Stainless steel or titanium Rack – Stainless steel (1.4571)
Operational depth	Up to 6000 m
Standard dimensions	Height – 1200 mm, Width – 250 mm, Depth – 220 mm
Chamber dimensions	Height – 1070 mm, Width – 220 mm, Depth – 220 mm
Weight	28 kg (without drives)

Application:

- **Seabed / water contact sampler and analyser**
- **Platform for in-situ sample analysis in response to injected solutions**

Features / Benefits:

- **Programmable with ease**
- **Allows stacking of multiple syringe samples for dedicated timeline**
- **Various sensors can be added (e.g.CO₂, oxygen, CH₄)**
- **Injection of active fluid for controlled redox measurements via onboard syringe sampler**
- **Stirrer to ensure even distribution within the probe**

Syringe Sampler

K/MT 115

A fully programmable subsea analysis instrument

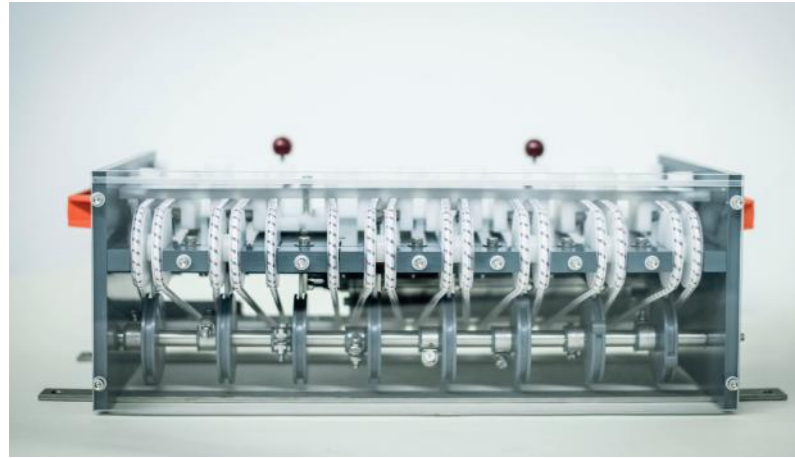

Scientific investigations that are easy in the lab are not so straightforward when they need to be conducted in the subsea environment with pressures of up to 600 bars. Our extensive range of products is designed to address these challenges, and the K.U.M. Syringe Sampler is an important addition.

The Syringe Sampler is a water-sampling instrument that comprises of a series of individually programmable syringes that can perform tests in-situ on the seabed over a period of up to two years.

Eight syringes are present in total, with one usually programmed to inject an active fluid into the probe containing high concentrations of the desired parameter (CO₂, O₂ etc). The remaining seven syringes are generally used to collect samples at different time intervals. The syringes can be designed in either glass or plastic depending on requirements.

With operational depths of up to 6000m, the Syringe Sampler can easily be deployed using the K.U.M. Lander along with the Benthic Chamber. Both are connected via plastic tubes, thus allowing water probes to be taken directly out of the chamber.

SYRINGE SAMPLER	
Number of syringes	8 (50 ml)
Battery	6 Alkaline D-Cells
Material	Glass or plastic
Operational depth	6000 m
Operational time	Up to 2 years
Dimensions	Height – 180 mm, Width – 460 mm, Depth – 270 mm
Weight	10 kg (without syringes & drive)
Mechanics	Electrical drive engine triggers camshaft

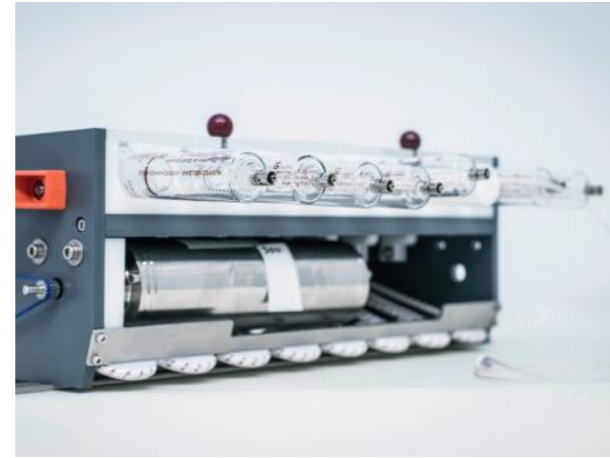

Application:

- Conducting in-situ experiments at seabed
- Injecting of desired chemical into probe to carry out measurements over time
- Collection of probe samples at different time intervals

Features / Benefits:

- Small dead volumes
- Possible to stack multiple Syringe Samplers
- Spring loaded, ultra low-power consumption
- Optional micrometre filter
- Luer-Lock connection
- Can be programmed in a browser using Wi-Fi
- Rubber cord driven mechanics (ensures a steady force is applied to avoid damage to filter)

Stirrer

K/MT 111

A highly efficient subsea liquids mixing instrument



When performing some critical sample measurements on the seabed, it is important that collected samples are thoroughly mixed to ensure a constant concentration throughout the solution. To ensure that subsea samples can be mixed efficiently in situ, K.U.M. developed the Stirrer.

The Stirrer is comprised of a mini-motor with a gear, all contained within a compact pressure-proof tube. The tube is supplied with external power via a pressure-proof subsea connector sealed using an O-ring. The Stirrer can be deployed to operational depths of up to 6000m.

The design of the Stirrer is very simple: once power is provided it will begin rotating with speed increasing linearly with voltage. The Stirrer slowly but steadily maintains equal concentration within the probe with best results achieved in the absence of a concentration gradient.

The Stirrer comes fitted with a magnetic coupling to ensure there are no consistency problems at the shaft, no friction forces to be overcome; and low power consumption during operations.

Application:

- In-situ sample mixing instrument for deep sea operations

Features / Benefits:

- Low power consumption
- Withstands extreme external pressure
- Compact design

STIRRER	
Revolution	50 – 200 U/min
Power	10 – 25 mA
Pressure	600 bar
Voltage	1.5V – 6V
Material	Titanium (TiAl6V4) or stainless steel POM
Operational depth	6000 m
Operational temperature range	-5 to +60 °C
Dimension (without sticks)	Diameter – 25 mm, Length – 130 mm
Weight	0.310 kg

An autonomous control system for most 12V appliances

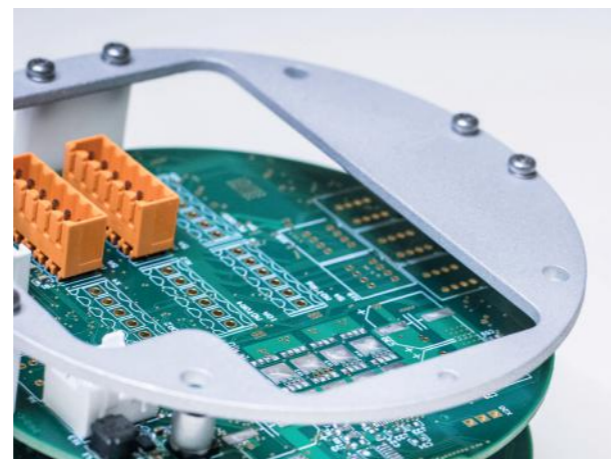

Experiments in marine environments may require the use of many machines to carry out specific mechanical or engineering tasks. Often an electronics unit is needed to ensure the full control of these different machines.

K.U.M. created the 4Tuna precisely for this purpose. Its modular design and programmable electronics ensure that a wide variety of different tasks can be accomplished autonomously.

The 4Tuna provides clients with autonomous control of most 12V appliances and, although initially introduced for use with the Sediment Trap and Lander, the unit's versatility has now proved its value across a wide array of services.

The 4Tuna is equipped with six power outputs that can be programmed independently. Users input the desired commands via a PC, with operations initiated via either a calendar setting or in response to an event. Once the task is completed each event is logged and can be transferred to a PC for review. User commands can be saved and repeated for future tasks using the integrated time-shift function.

The internal electronics of the 4Tuna are protected when power is supplied to the motor (or depleted) as the voltage is ramped up (or down) steadily to avoid electronic 'backstroke' within the inductive coils. Additionally, the 4Tuna has very low power consumption to allow for extended operations.

Application:

- **Autonomous electronic control of 12V appliances in marine setting**

Features / Benefits:

- **Calendar or event autonomous control**
- **Compatible with most 12V appliances**
- **Save and repeat work lists for future use**
- **Low power consumption**
- **Voltage ramping to avoid electronic 'backstroke' in the motor's inductive coils. Electronics can be programmed to process complex inputs and trigger events**

4TUNA	
Motors	Supply up to 6
Sensors	Up to 12
Power output	Up to 10A
Voltage compatibility	12V appliances
Power consumption	25 uWatt (idle) 7 mW (in operation, electronics only)
Dimensions	Diameter – 108 mm, Height – 300 mm

A customisable pressure-proof instrument housing

Protecting instruments used in deep-sea operations is vital not only for the success of any investigation, but also to avoid environmental contamination and potential financial losses. Today, with many years of experience working with titanium, K.U.M. is internationally renowned for producing high quality deep-sea pressure-proof tubes.

K.U.M.'s Pressure Tubes are manufactured using grade 5 titanium to provide ideal protection from corrosion and in high-pressure environments. Ideal for use on any deep-sea investigation, K.U.M.'s instrument housing Pressure Tubes can be customised to any diameter and are tested within K.U.M.'s pressure tank prior to delivery.

Depending on specific customer requirements, K.U.M. Pressure Tubes can also feature a range of different accessories including caps, connectors or plugs, threads, camera windows, grips, rotating axis and different sensors.

PRESSURE TUBES			
Connectors	Subconn, Seacon, Impulse, ODI and others		
Openings	Double O-ring sealing (Pressure valve on request)		
Maximum pressure	up to 1200 bar		
Life expectancy	20 years		
Operational depth	Up to 12000 m		
Material	Titanium (TiAl6V4)		
Dimensions	Customisable upon customer request Examples:		
	Inner diameter		Inner length
	12 mm	X	25 mm
	95 mm	X	480 mm
	130 mm	X	500 mm
	150 mm	X	650 mm
	325 mm	X	900 mm
	800 mm	X	2000 mm



Application:

- **Deep-sea instrument protection**

Features / Benefits:

- **Corrosion resistance**
- **Titanium 44% lighter than steel**
- **Fully customisable**
- **External memory available**
- **Wide aperture camera windows**
- **Glass dome for lighting**

A robust and durable deep-sea camera casing



Many instruments, such as cameras, are not designed to withstand deep-sea pressures and so they require a protective housing during deployment in the marine environment.

K.U.M.'s pressure-proof titanium Camera Housing has been designed to offer protection from both corrosion and high pressure down to operational depths of 12000m. It comes equipped with a camera window to the front and a connector port in the rear. The camera window is flat and made from either boro-silicate or sapphire to ensure that high optical-quality particle cameras can continue to perform to the highest standards.

Furthermore, when used with an optical dome, special camera attachments can be designed to place the virtual focal point on the centre of the dome to ensure the highest possible picture quality.

To date, the K.U.M. Camera Housing has played a crucial role in many experiments including the use of zoom cameras in subsea particle detection.

Customisation is also available – with unique housings often developed to meet the requirements of the specific camera equipment used by customers.

Application:

- Deep-sea protective housing for cameras, optical data transmitters and other instruments

Features / Benefits:

- Dimensions fully customisable upon request
- Optical glass for highest resolution
- Flat surface for high image fidelity
- Dome port for monitoring procedures or light fittings

CAMERA HOUSING	
Opening angle	2 x 44°
Camera window shape	Plain window Cone shaped 2 x 44° (More suited for macro images)
Tube material	Titanium (TiAl6V4)
Window material	Borosilicate glass Perspex Sapphire
Operational depth	12000 m
Compatible equipment	Video Cameras Recorder Electronics Micro colour camera Optical data transmitters

A compact deep-sea corer and sample transportation device



In many marine investigations, core samples are essential for ascertaining the bulk properties of underlying sediments, but obtaining these cores from the seabed with conventional multi-corer can be very challenging.

Conventional multi-corer have a minimum area size of 4m² and a minimum height of 3m and often require assembly on the vessel. In addition, due to their weight and height, they typically do not fit within a standard 20-foot shipping container, and it can be dangerous to operate them onboard with typically a large crane or frame being required.

To address this, K.U.M. developed the MiniMuc, a much smaller, deep-sea, core sampler with an area of just 1m² and height of 1m. Significantly, no assembly is required as the MiniMuc is shipped turnkey, ready to operate.

Once on the seabed, this compact corer is capable of collecting four probe samples in a single deployment. Seabed penetration is guaranteed by the various lead weights. Once penetration is complete, mechanical arms on the MiniMuc are released, closing the core tubes and extracting them from the seabed ready for transportation to the surface.

Application:

- Seabed core sampling and transportation

Features / Benefits:

- Multiple lead holdings for optimal and successful seabed penetration
- Acts a transportation device as well as core

MINIMUC	
Probe sampling	4 Core tubes (PMMA) Dimensions: Sand – 40 mm diameter x 600 mm length Slick – 100 mm diameter x 600 mm length
Material	Frame: Stainless steel (Optional non-corrosive titanium) Tubes: PMMA (Plexiglas)
Operational depth	6000 m
Dimensions	Diameter – 1000 mm, Width – 1000 mm Height – 1000 mm
Transport dimensions	Length – 1 m, Width – 1 m, Height – 1 m
Weight	100 – 220 kg (Dependant on lead weights needed for seabed penetration)

A heavy-duty seabed rock collector



Samples of rock, nodules or cobbles from the seabed can provide geologists with valuable insights into the underlying strata and its properties. To obtain these samples efficiently and safely, K.U.M. developed the Chain Bag Dredge.

Attached to a vessel, the dredge is simply dragged across the desired seabed location, collecting large rock samples while allowing for unconsolidated sediment to wash out. The dredge is available in two sizes and can be optionally equipped with four sediment tubes mounted to the corners of the dredge mouth.

Based on customer information about the load strength of their vessel's wire rope, K.U.M. will provide dredge and safety wire ropes with appropriate load strength. Dredge wire rope should have the lowest load strength, while safety wire rope should have a lower load strength than the vessel's wire rope.

The vessel wire rope is attached directly to both the short dredge wire and the safety wire, forming a dual-wire setup with the dredge wire acting on the front of the dredge and dragging it along the seabed. The safety wire is attached to the back of the dredge for use during the recovery process, if required. The dredge comes equipped with a chain bag to collect the rocks in which cell dimensions can be customised to consolidate a sample size in line with customer requirements.

If the dredge bag gets stuck, the dredge wire can be broken by applying a force in excess of its breaking load. Once the dredge wire rope is broken, the vessel's wire rope is only attached to the rear of the dredge via the safety wire rope and pulls the dredge away from the rock, rather than towards it. In this way, although the samples may be lost, the dredge itself can be recovered safely. In the rare case that the rescue procedure fails, the safety wire rope can be broken as well. Although the dredge itself will be lost, the vessel's wire rope is freed and can be recovered safely.

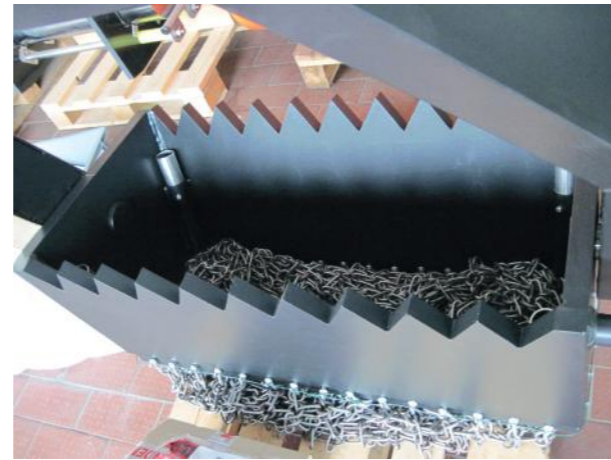

Application:

- Collection of rock samples from the seabed

Features / Benefits:

- Designed to wash out unconsolidated sediments from collection area
- Four optional sediment collection tubes can be attached
- Safety mechanism in place for dislodging of dredge and recovery
- Chain bag dimensions can be customised to customer request

CHAIN BAG DREDGE		
Product	Type 1 (K/MT 9000)	Type 2 (K/MT 9001)
Mouth	500 – 950 mm	950 – 1400 mm
Length	1200 mm	2000 mm
Weight	Approx. 300 kg	Approx. 500 kg
Material	Steel	Steel
Dual wire setup	Dredge wire rope Safety wire rope	

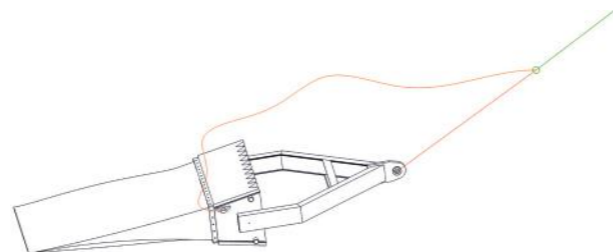

A sediment-core protective casing and storage rack



Sediment cores and samples from the seabed help geologists to determine the lithology of the underlying strata and associated characteristics. It is of utmost importance that the preservation, storage and transport of these samples are conducted safely to avoid any damage or contamination.

K.U.M. has designed a variety of Liner Tubes and D-Tubes as well as an associated Storage Rack system for all core handling and storage needs.

Liner Tubes

These reside within the corer instrument and act as the first contact with the sediment core. Once all cores are collected, the Liner Tubes can be cut lengthways to present a cross-section view along the core, ready for geological analysis. Once completed the cores can be taken and placed safely into D-Tubes.

D-Tubes (Sediment Core Storage)

These are for the long-term storage of sediment cores, providing protection from contamination and negating moisture loss. After being placed into the Liner Tubes and cut in half, each segment of core is then placed into a D-Tube. Humidity is self-regulated by the inclusion of a wet synthetic sponge and each tube includes two lids.

Storage Racks (Grid Box)

These are designed to be transported in standard 20-foot containers and allow for vertical stacking up to 6m. The rack is comprised of a galvanised steel frame, two insertable grids and a side grid. Each core segment stored can be separately accessed from the storage rack.

Application:

- Storage and protection of sediment cores

Features / Benefits:

- Each core segment is separately accessible from Storage Rack
- Storage Rack designed to fit within 20-foot container
- Wet synthetic sponge for humidity control inside the D-Tube

LINER TUBES	
Dimensions	KL 125: Ø125mm x 2,5 mm, up to 5000 mm KL 90: Ø90mm x 2,7 mm, up to 5000 mm
Compatibility	KL 125 compatible with D-Tube KR 135 KL 90 compatible with D-Tube KR 100
Material	PVC
Colour	Grey, transparent
Accessories	Lids for liner tubes

D-TUBES (SEDIMENT CORE STORAGE)	
Dimensions l x w x h (mm)	KR 135 1600 x 135 x 73, 1050 x 135 x 73 KR 100 1600 x 100 x 55, 1050 x 100 x 55 or other length
Compatibility	KR 135 compatible with Liner tube KL 125 KR 100 compatible with Liner tube KL 100
Material	PVC
Colour	White, coloured lids
Accessories	Synthetic sponge, special glue

(STORAGE RACKS (GRID BOX))	
Dimension	Length – 1653 mm, Width – 1136 mm, Height – 680 mm
Material	Galvanised steel
Weight	60 kg

Titanium Pump

K/MT 405

A compact, pressure-proof, deep-sea pump

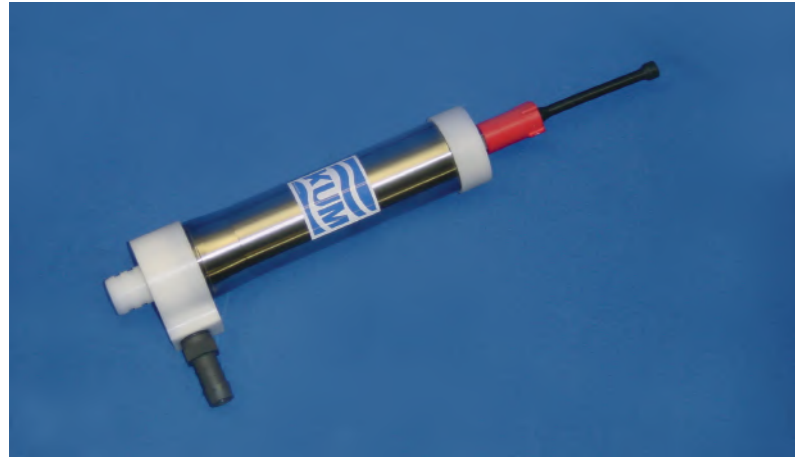

Imagine a study is being conducted to determine the level of manganese dissolved in seawater (the results will aid in locating manganese nodule deposits). As there is no specific 'manganese sensor' available to conduct this study, vast volumes of water samples must be collected due to the very low concentrations of the mineral.

Alternatively, a deep-sea pump can be used to collect and filter the desired sample in situ. K.U.M.'s Titanium Pump meets this need. It is a compact pump enclosed within a pressure-proof titanium housing that can operate to depths of up to 6000m.

The pump is composed of a centrifugal pump head and a ball bearing motor, components that are magnetically coupled together through the housing to avoid water penetration. This negates the need for additional sealing rings within the shaft.

Power comes from an external underwater SubConn-Micro connection. An internal electronic unit is also available for counting the revolutions of the pump, which will help to determine the exact volume that has been pumped through the filter. This, in turn, will allow for the precise calculation of the concentration of any given element in the seawater.

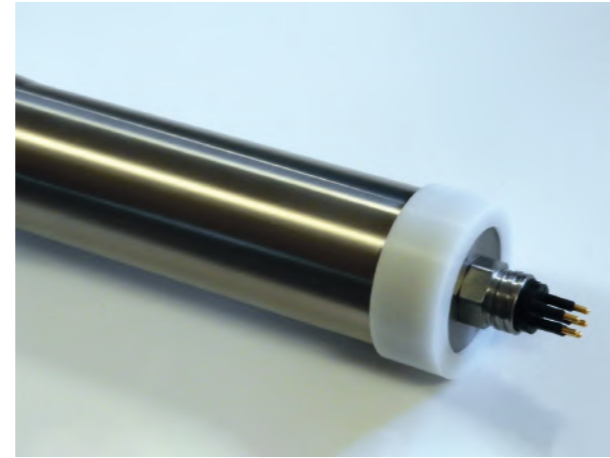

Application:

- The collection of water probes in marine environment
- Pumping of sample into storage instrument

Features / Benefits:

- Magnetically-coupled components to combat water penetration
- Allows for additional components to be incorporated

TITANIUM PUMP	
Power supply	External supply through 4-pin SubConn-Micro connector
Voltage	10 – 17 V
Impulse output	5V TTL: 1 impulse / revolution
Material	Pump head & End Cap – POM (Polyoxymethylene) Motor housing – Titanium
Operational depth	6000 m
Dimensions	Diameter – 51 mm, Length – 290 mm
Weight	1.53 kg (air) 1.00 kg (water)
Components / Features	Ball bearing motor Magnetic coupling motor-impeller Impeller: Ceramic axis and bearing

Matemo

K/MT 1099

A deep-sea tilt-angle recording device



One of the many challenges in deep-sea research is establishing the exact horizontal position of an instrument on the seabed. This is a very important factor for instruments including samplers and sediment traps, where any uncertainty can lead to inaccurate data collection and its misinterpretation.

K.U.M.'s deep-sea inclinometer Matemo is designed to address this issue. Prior to operation, Matemo can be attached to equipment while onshore to determine the tilt angle of the system on a known surface; this value can then be automatically deducted from final measurements taken during operation, thus restoring the norm.

Matemo is designed to record tilt angle in two directions (X and Y) – which are programmed by its software – MATUI (Multi Axis Tiltmeter User Interface). MATUI allows the user to configure measurement interval, actual time or start time delay of the measurement. Once the investigation is concluded, data can be downloaded and displayed in a graph or exported for external analysis. The data, as well as the settings, are saved in non-volatile memory and will remain safe regardless of the battery being depleted or replaced.



Application:

- Determination and recording of instrument tilt
- Tilt correction wherever gradient of the ground distorts measurements

Features / Benefits:

- Data can be downloaded and displayed in graph (integrated quick view) or exported for analysis
- Data and settings are saved regardless of battery exhaustion or replacement

MATEMO	
Max number of measurements	65500 measurements per axis (X,Y)
Measurement interval	1 Second – 1 day
Measurement range	±80° per axis
Resolution	0.1°
Absolute fault	(within ±60°): ±0.1° (outside of ±60°): ±0.5°
Power supply	3.6V DC Lithium primary battery (qty. 1); ex. Saft 33.600 with soldering tag (D-size)
Back-up battery	3.0V DC Lithium primary battery (CR123A, qty. 1)
Material	POM (Polyoxymethylene) – Shallow water Titanium – Deep sea
Operational depth	POM housing – 200 m Titanium housing – 6000 m
Operational temperature range	-20° to +85° (operation, storage and transport)
Operational time	Up to 3 years
Dimensions	Diameter – 64 mm, Height – 169 mm

A compact and powerful marine force generator

If an autonomous deep-sea experiment requires a mechanical drive to carry out any task involving movement or the expulsion of force, then a reliable and powerful drive engine is needed – and it has to be one that works even in a high-pressure environment.

The majority of drives available on the market today are designed for one very specific purpose and cannot be used for a diverse set of tasks. K.U.M.'s compact and lightweight Drive Unit is, by comparison, highly customisable to meet a variety of customer requirements.

The power supply, housing material, torque, revolutions, shaft ends and connectors can all be designed, manufactured and tested to meet specific requirements. Furthermore, all Drive Units are comprehensively tested for functionality and strength in K.U.M.'s own pressure tank prior to delivery.

The Drive Unit can provide an enormous torque of up to 15Nm and its turning is counted in steps of 15 degrees by its internal electronics. Additionally, shaft positioning can be achieved with a precision of 1/16 revolutions attributed to the internal electronic system.



DRIVE UNIT	
Revolution	0.5 – 4 Upm (at the shaft)
Torque	4-10 Nm continuous operation 15 Nm short operation
Impulses	1-16 each 360°
Voltage supply	6V, 12V, 24V, 36V*, 48V* (* – requires larger housing)
Material / weight	Steel (1.4571 or 1.4539): 5.4 kg Titanium (TiAl6V4): 3.5 kg
Operational depth	Up to 12000 m
Dimensions	Diameter – 70 mm, Length – 350 mm

Application:

- Moving heavy objects or parts against high friction
- Controlled movement of any object in deep sea

Features / Benefits:

- Highly customisable allowing for a wide array of tasks to be conducted
- Generates powerful movement force in deep sea environments
- Titanium build offering excellent protection from corrosion and pressure

High strength titanium shackles, chains and rings



K.U.M. manufactures and supplies a wide range of shackles, chains and rings – all made from titanium to provide high durability and corrosion protection.

Shackles are further protected against fretting through the application of a cerid-coating. Chains can be manufactured in a variety of lengths based on customer requirements. Rings are available in two sizes.

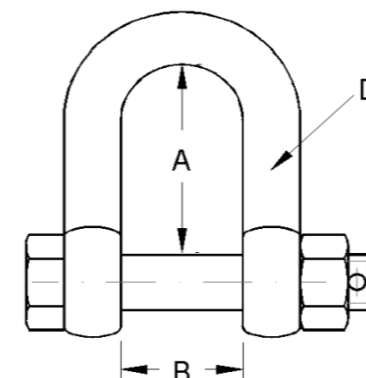
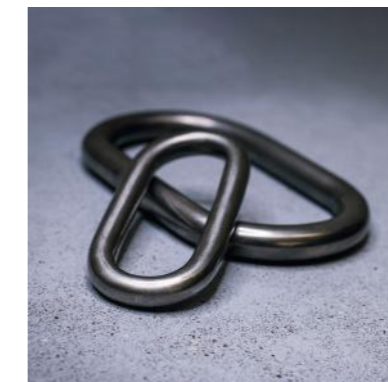

Application:

- Shackle – Primary connecting link in all manner of rigging systems
- Chains – Lifting of heavy load or transferral of power within machines
- Ring – Interlinked to create chain or to hold objects together

Features / Benefits:

- Chain length is based on customer requirements
- Cerid-coating to protect against fretting
- Titanium build offering protection from corrosion and high durability

SHACKLE U-7500-N	
Breaking load	10000 kg
Weight	0.340 kg
Dimensions	Diameter – 15 mm Length – 94 mm Bolt diameter – 17 mm A – 55 mm B – 32 mm

CHAIN	
Total chain length	Customisable upon customer request
Material	Titanium (TiAl6V4)

RINGS	
Ring 1	Breaking load – 5000 kg Total length – 124 mm Total width – 54 mm, weight 140 g
Ring 2	Breaking load – 4000 kg Total length – 167 mm Total width – 101 mm, weight 355 g

Swivel

K/MT 1051

A maintenance-free titanium swivel



Conventional swivels can be extremely susceptible to corrosion due to the steel ball bearing used in standard designs. In order to avoid direct contact with the seawater, bearings have traditionally been sealed and filled with oil, however even the smallest penetration of water can cause destructive corrosion.

To address this, K.U.M. designed a high-tensile titanium Swivel that uses a ceramic ball bearing instead of a steel one. This puts the risk of corrosion within the Swivel at zero. The result is a Swivel that is maintenance-free and offers maximum protection even if seawater penetration does occur.

Application:

- Connection which allows linked objects to rotate horizontally or vertically
- Moorings of instruments

Features / Benefits:

- Corrosion and rust-resistant ceramic ball bearing design
- Maintenance-free

SWIVEL	
Load capacity	1500 kg
Ball bearing material	Ceramic
Material	Titanium (TiAl6V4)
Dimensions	Diameter – 78 mm Height – 145 mm Eye Diameter – 22 mm
Weight / air	110 kg
Weight / water	0.850 kg

Scoop Net

K/MT 11081

A robust ROV sample-collection tool



The introduction of ROVs has greatly enhanced the ability of marine scientists to carry out a wide range of subsea investigations, however even ROVs still require complementary tools in order to tackle certain tasks.

The K.U.M. Scoop Net has been designed for use with ROVs in order to collect subsea samples. The net features a T-shaped handle that can be easily attached to an ROV to scoop and hold samples until they can be recovered. Additionally, a metal blade is placed at the bottom of the Scoop Net aperture to protect the net from tearing as well as to aid in the collection of samples (e.g. shells).

The Scoop Net is available either as Polyamide 6, 1x1 mm mesh, which has an operating temperature of up to 50°C, or as PTFE glass fibre 1x1 / 2x2 / 4x4 mm mesh with an operating temperature of up to 250°C.

Application:

- Collection of subsea and seabed samples with use of ROV
- Sample collection in high temperature environments (e.g. hydrothermal vents)

Features / Benefits:

- Glass fibre mesh net can be used in high temperature environments and have three different mesh sizes
- Easy to operate with different ROV manipulators

SCOOP NET	
Material	Frame and handle – Stainless steel 1.4571 Net – Polyamide 6 or PTFE glass fibre
Net aperture dimensions	Width – 200 mm, Height – 154 mm Frame thickness – 10 mm
Net dimensions	Length – 300 mm Mesh size – 1 mm, 2mm, 4mm

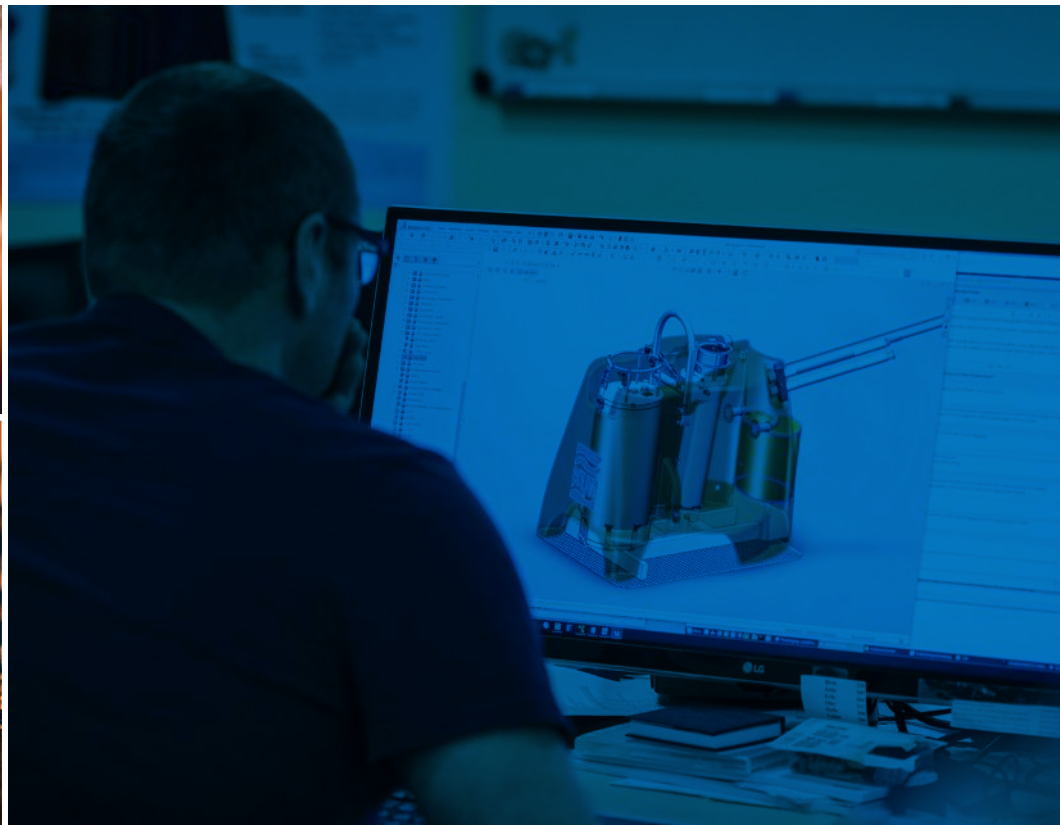
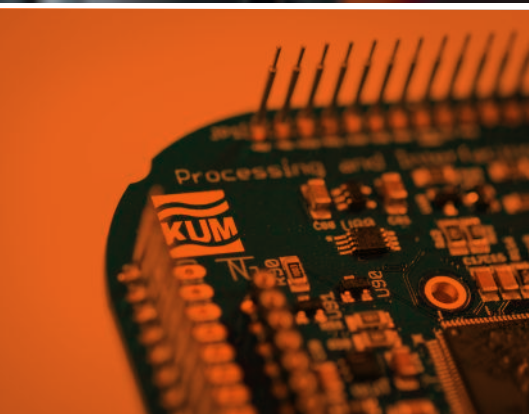

K.U.M.
Umwelt- und Meerestechnik Kiel GmbH

Wischhofstr. 1–3
Bldg. 15/16
24148 Kiel, Germany

T: +49 431 72092-20
E: kum@kum-kiel.de

kum-kiel.de